

Place SAM 01 profile block on side spindle 2.
 Place SAM 4152T1 profile block on side spindle 3.
 Place SAM 4152T2 profile block on the first top spindle.

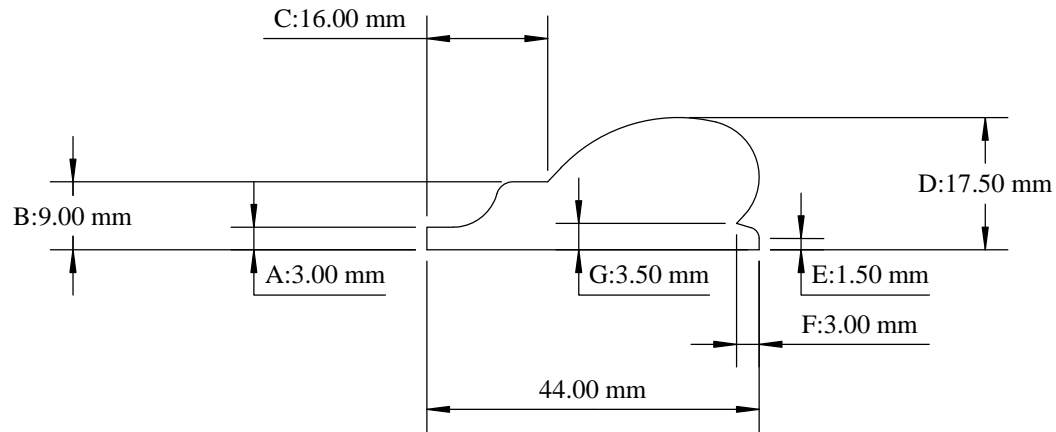

Manufactured from 18mm material

PRINTED COPY UNCONTROLLED

AREA MACHINED AWAY 253.87 SQMM.

MOULDER	ANY
PASSES	1
DRAWN BY	S McMaster
DATE	27/10/16
SCALE	1:1
REV:	1
AUTH:	
TOLERANCE	+/- 0.5MM

SAM MOULDINGS

Newpark Industrial Estate Greystone Road Antrim BT41 2RU

Tel : (028) 9442 8288 Fax : (028) 9442 8244

Website: www.sammouldings.co.uk Email: info@sammouldings.co.uk

SAM 4152